

### Installation instruction

Photocell type KJ2005 consists of transmitter and receiver (Fig.1). A beam of infra- red is sent from transmitter to receiver, which creates non- material barrier. The appearance of an obstacle (for example a car) in the zone of working photocell generates appropriate alarm signal. The impulse is sent to control device which either stops the gate or starts move of the gate in opposite direction.

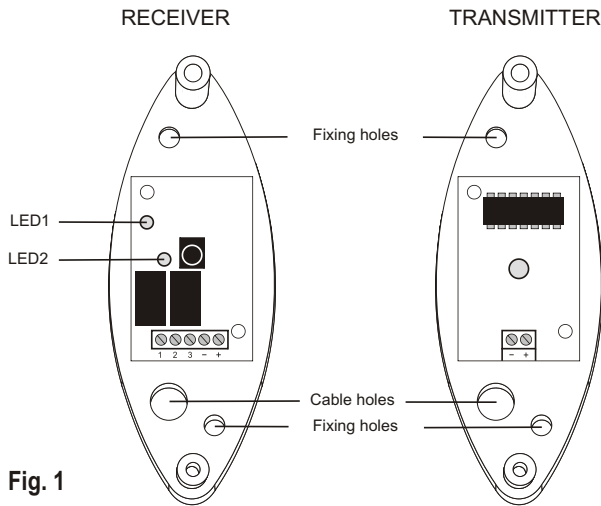

Fig. 1

Photocell KJ2005 is made for the gates with propulsion which are equipped with power restrictor according to attachment A of the legal norm EN 12453 or power restrictor specified in 5.1.1.5 of legal norm EN 12453. Photocell KJ2005 should be used in gates with propulsion made for vehicle movement.

#### Specifications

Range	16m
Power supply	12V ÷ 24V ac/dc
Type of joint relay	NC/ NO
Power consumption	Transmitter max. 40mA
	Receiver max. 30mA
Joint relay contact	max. 0,5A
Cross-section of power cables	max. 0,5mm <sup>2</sup>
Operating temperature	-25°C ÷ 55°C
Dimensions	96x39x30(H)

#### Installation of photocell KJ2005

To work properly the transmitter and receiver must be installed in a straight line on the side of gate 40-60 cm above the ground. Because of photosensitive components in the electronic structure, it is recommended to install the receiver on the side of the gate which is less exposed to the sun's rays.

**Warning!** Do not install mirrors, screens etc.

Install the photocell type KJ2005 to the wall or column using the two screws. For this purpose mark points of drilling to install photocell (transmitter + receiver) by putting its base in the place where wires come out of the wall so that tighten slats on the electronic plate are on the bottom side. Next drill holes of appropriate diameter and put there anchors. Pull the wires through the hole in the lower part of the base and then screw on the photocell. The holes where the wires go through should be sealed up (e.g. with silicone).

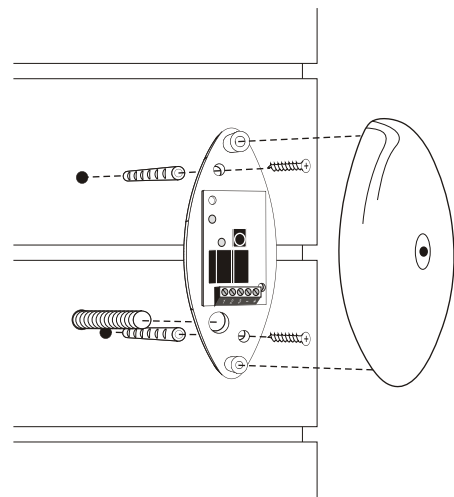

Fig. 2

#### Connecting the photocell KJ2005

##### Transmitter TX

"-" - power supply 12V ÷ 24V (voltage dc - negative)  
 "+" - power supply 12V ÷ 24V (voltage dc - positive)

##### Receiver RX

1 - NC  
 2 - COM common relay  
 3 - NO  
 "-" - power supply 12V ÷ 24V (voltage dc - negative)  
 "+" - power supply 12V ÷ 24V (voltage dc - positive)

Install the powering wires (voltage 12V ÷ 24V ac/dc) to the clamps "-" and "+" in the transmitter and the receiver. Clamps "-" and "+" are important in case of connection to the direct current dc.

#### Signal output from the photocell

1-2 - joints normally closed NC  
 2-3 - joints normally opened NO

In Fig. 3. you can see connection of the photocell KJ2005 to the control panel with the signal output to the photocell with joints normally closed NC (in case of control panel with signal output joints normally opened NO, you have to install wires to "2" and "3" on the joining strip of the receiver).

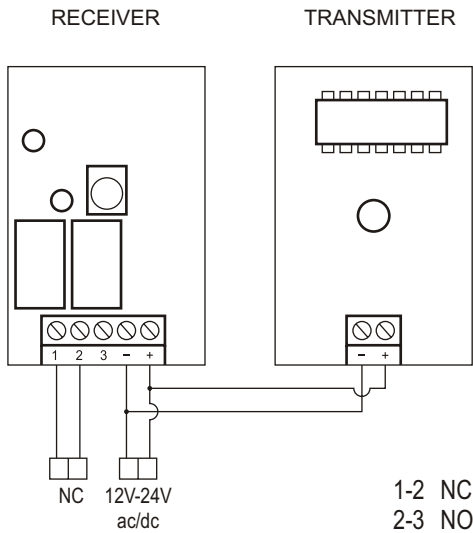

Fig. 3

**Checking connection of photocell type KJ2005**

Install wires powering up the photocell to receiver and transmitter. Then install wires of outputing signal photocell. **Put the upper side of the case on the transmitter (pay attention to the thicker bolt, it must be on the upper side).**

Shining green LED1 means the steady condition. Shining red LED2 means that there is an obstacle on the way of the photocell (state of alarm). Put the upper part of the case on the receiver (the upper part of case should be reinstalled using a flat screwdriver).

**Testing**

Test:Automatic system of the gates must be tested by the personnel with right qualifications according to EN 12453.

Testing:

1. Supply power only to reciever and check if there was an alarm signal.
2. Then supply power to transmitter and check if steady condition occured.
3. Move cylinder (5cm in diameter and 30cm in lenght) crossing optical axis between transmitter and receiver, first close to the transmitter TX, next close to receiver RX, and then half way between them. Each time photocell should switch from state of steady condition to alarm state, what should cause proper reaction from the control panel (e.g. stopping

the gate).

**Maintenance**

All the tests mentioned before should be made with intervals no longer then 6 months. It is important to remember that photoelectric lens should be clean.

Producer/ Distributor